



**Known for Reliability
Since 1921**

Fish Processing Band Saws



(Design A)
Model 44SSFH-LP-PGF
Stainless Steel, Fixed Head, Low Profile,
High Speed Saw, with Precision Gauge
Fence for Frozen Fish Block Portion
Control Fish Products



(Design B)
Model 44SSFH-LP-FS-R
Stainless Steel, Fixed Head, Low Profile,
High Speed Saw, Fish Steaking/Retailing



(Design C)
Model 44SSFH-LP-HDFFT
Stainless Steel, Fixed Head, Low Profile,
High Speed Saw, with
Heavy Duty Front Fixed Table
Breaking/Trimming



44SSFH-LP SERIES

MODEL SPECIFICATIONS

MODELS	A Model 44SSFH-LP-PGF				B Model 44SSFH-LP-FS-R			C Model 44SSFH-LP-HDFFT	
Motors	HP	KW	TYPE	VOLTS	AMPS	HERTZ	PH	STATUS	STD = Standard EC = Extra Cost MR = Moisture Resistant
	5	3.7	MR	208-220/440	15.7-14.8/7.9	60	3	STD	
	5	3.7	MR	575	5.9	60	3	EC	
	5	3.7	MR	220/380-415	17.8/10.3-9.4	50	3	EC	
Construction	Stainless steel unitized base, head and door structure; legs, channel, assembly tables; some components non S.S.								
Standard Eq.	Two saw blades • Operation and Safety manual • Safety wall poster • Safety end cut pusher plate (except fixed table saw)								
Saw Blade	135" (3429mm) L x 5/8" (16mm) W x .018 (.45mm) thick -hard tooth				135" (3429mm) L x 5/8" (16mm) W x .022 (.56mm) thick -hard tooth				
Blade Guide	Upper and lower blade backup guide assemblies, with carbide long-life inserts, removable as an assembly								
Blade Speed	Approx. 5000 (1524m) feet per minute				4000 (1219m) feet per minute - higher f.p.m. blade speed available				
Blade Wheels	18" (457mm) single flange, cast iron, nickel plating, upper wheel assembly removable - Opt. S.S. blade wheels available								
Blade Guide Bars	Double (reinforced) stainless steel saw guide bars								
Blade Tension	Factory preset tension spring in housing with screw tensioning handle, located under upper wheel								
Blade Cleaning Unit	Stainless steel body with long-life carbide guide inserts, steel saw cleaners, removable as a unit for easy cleaning (assembly also adjusted as a unit)								
Bearings	Heavy duty tapered roller bearings used in upper saw wheel hub and lower bearing housing assembly								
Dust Catch Pan	Deep rounded corners poly pan sealed off from other areas of base structure, accessible through hinged door								
Drive System	Tension adjustable, non-slip, silent V-belt								
Meat Carriage	25½" (647mm) L x 17½" (444mm) W stainless steel with 8, 1-7/16" diameter; (36.5mm) stainless steel EZ-flow bearings						Not applicable		
Legs	Stainless steel welded legs with 4 adjustable leg bolt levelers								
Motor Compartment	Sealed off from meat contact areas, easily accessible through removable panel door								
Platter	Right rear platter stationary, left rear platter removable				Stainless steel rear platter, removable by releasing push-pull hold down rods				
Power Switch	Watertight magnetic with thermal overload and under voltage protection								
Pusher Plate	Standard						Not applicable		
Meat Gauge Plate	Not applicable				Adjustable from 1/16" (1.6mm) to 6½" (165mm) locks in position; assembly removable for cleaning			Not applicable	
Options (Extra Charge)	A,B,C - Power cord (12ga.) and plug; S.S. saw blade wheels for 5/8" (16mm) saw blade, Cast saw blade wheels for 1" (25.4mm) saw blade; Longer S.S. hex (leg) bolts								
Certifications	N.S.F. • U.S.D.A.								
Weight	Uncrated: 600 lbs. (272kg); Crated: 700 lbs (318kg); Dims. Crated: L 54" (137cm) x W 45" (114cm) x H 83" (211cm) All weights and dimensions are approx. depending on design and options selected								
Legend	FH = fixed head; FS = fish steaking; HDFFT = heavy duty fixed front table; LP = low profile; PGF = precision gauge fence; R = retailing; S.S. = stainless steel								

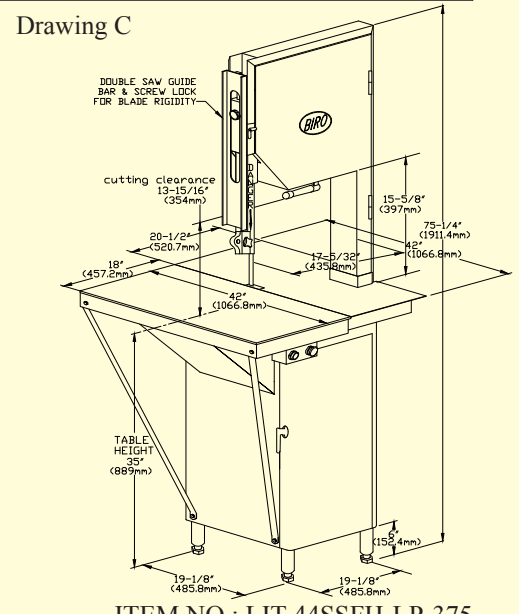
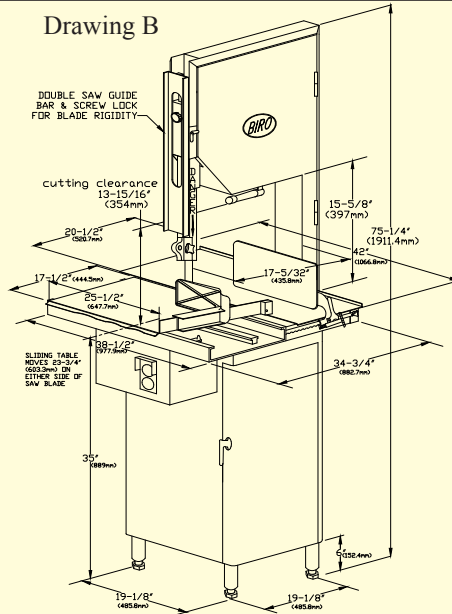
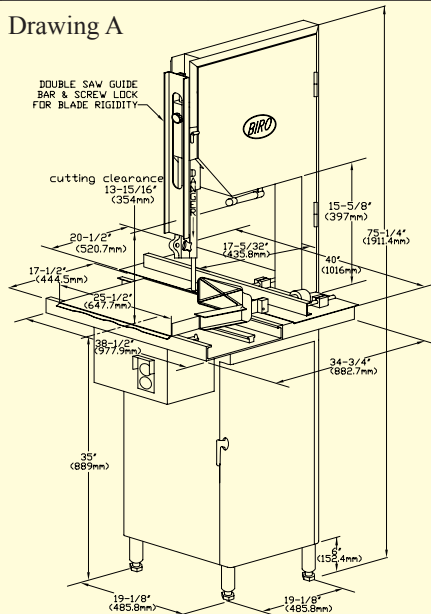

All specifications contained herein are subject to change without notification.

ITEM NO.: LIT-44SSFH-LP-375
FORM NO.: Md 44SSFH-LP-375-5-16-3-B

Phone: (419) 798-4451
Fax: (419) 798-9106

Service is available
from locations worldwide

www.birosaw.com
sales@birosaw.com